

General

The plug-in SLC module provides power for and handles communications to the analogue addressable devices. The SLC continuously monitors the analogue values of all devices and displays this value on the control panel as a percentage of the alarm threshold value. Up to 254 addresses (500mA max load) can be connected to a single SLC. The addressable devices use soft addressing using the VDOT-AD2 handheld programming tool which helps minimise the potential for error and reduce the installation time associated with traditional hard addressing. The AUTO-LEARN facility provided in the Velocity series control panel saves considerable time and effort when installing a new loop or when changing device configuration.

It allows the system to learn for itself what devices have been installed on the loop.

Installation

The MMP panel uses the expansion port number to reference modules. It is recommended that any SLC modules are fitted first to the first expansion ports, so that the loop circuit numbers follow a logical sequence (loop 1 in port 1, loop 2 in port 2 etc.)



ATTENTION: THE PANEL MUST BE POWERED DOWN, AND DISCONNECTED FROM THE BATTERIES BEFORE INSTALLING OR REMOVING ANY MODULES.

1. Ensure that the installation area is free from any cables or wires that may get caught, and that there is enough space on the DIN rail to mount the module. Also ensure that the DIN clip underneath the module is in the open position.
2. Place the module onto the DIN rail, hooking the metal earth clip underneath onto the rail first.
3. Once the earth clip is hooked, push the bottom of the module onto the rail so that the module sits flat.
4. Push the plastic DIN clip (located at the bottom of the module) upwards to lock and secure the module into position.

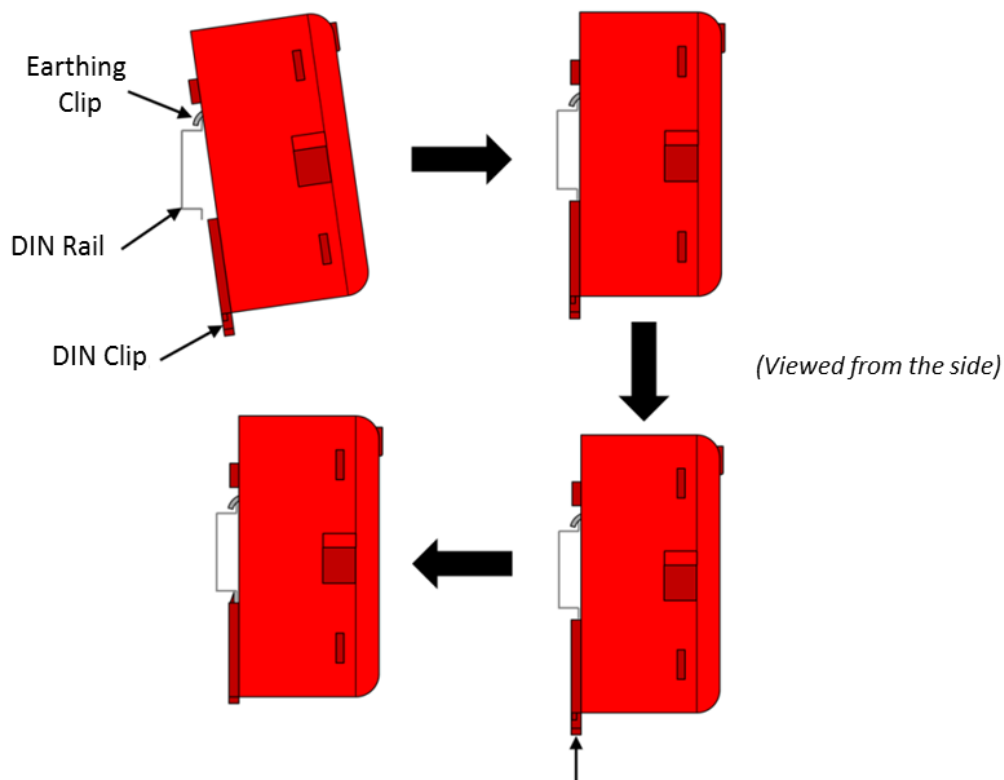

5. Once the module is secured to the DIN rail, simply connect the supplied CAT5E cable to the module's RJ45 port.
6. Connect the other end of CAT5E cable to the nearest unoccupied RJ45 port on the termination PCB.

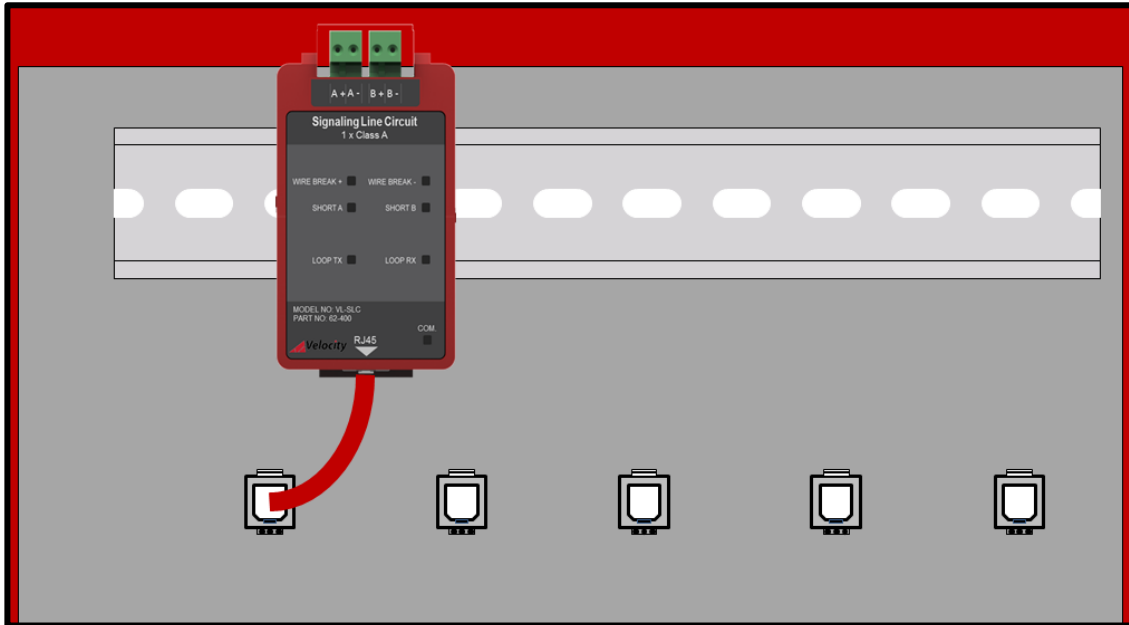

TRM RJ45 Port Address Designation

Each RJ45 port on the Velocity termination has its own unique port address. This port address is important to keep note of as it is displayed on Alarm/Trouble messages and is used when configuring or setting up cause and effects on the panel (See Velocity MMP operation manual GLT-261-7-2).

Securing the modules

The modules are designed to clip together to make them more secure. In addition, the MMP panel is supplied with Din rail stoppers. These should be fitted before the first module, and after the last module on each rail.

Before Powering the Panel On

1. To prevent the risk of a spark, do not connect the batteries. Only connect the batteries after powering on the system from its main AC supply.
2. Check that all external field wiring is clear from any open, shorts and ground faults.
3. Check that all the modules have been installed properly, with correct connections and placement
4. Check that all switches and jumper links are at their correct settings.
5. Check that all interconnection cables are plugged in properly, and that they are secure.
6. Check that the AC power wiring is correct.
7. Ensure that the panel chassis has been correctly earth grounded (See NFPA 70).

Before powering on from the main AC supply, make sure that the front panel door is closed

Power on Procedure

1. After the above has been completed, turn the panel on (Via AC Only). The panel will follow the same power up sequence described in initial power up section above
2. The panel will now display one of the following messages:

Message	Meaning										
 <p style="text-align: center;">No Modules</p>	<p>Panel has not detected any modules fitted during its power up check.</p> <p>Power down the panel and check that the expected modules are fitted, and that all module cables are correctly inserted.</p> <p>Note that the panel will need at least one module fitted to run.</p>										
<table border="1" style="width: 100%; border-collapse: collapse;"> <tr> <td style="width: 5%;">001</td> <td style="background-color: #00FF00;">New module : SOUNDER CLASS A</td> </tr> <tr> <td>002</td> <td>Empty port</td> </tr> <tr> <td>003</td> <td>Empty port</td> </tr> <tr> <td>004</td> <td>Empty port</td> </tr> <tr> <td>005</td> <td>Empty port</td> </tr> </table> <div style="display: flex; justify-content: space-between; align-items: center; margin-top: 5px;"> ✓ ▽ ▲ </div>	001	New module : SOUNDER CLASS A	002	Empty port	003	Empty port	004	Empty port	005	Empty port	<p>The panel has detected a new module added to a port that was previously empty.</p> <p>This is the usual message seen the first time a panel is configured</p>
001	New module : SOUNDER CLASS A										
002	Empty port										
003	Empty port										
004	Empty port										
005	Empty port										
<table border="1" style="width: 100%; border-collapse: collapse;"> <tr> <td style="width: 5%;">001</td> <td style="background-color: #FFFF00;">Changed module : SOUNDER CLASS A</td> </tr> <tr> <td>002</td> <td>Empty port</td> </tr> <tr> <td>003</td> <td>Empty port</td> </tr> <tr> <td>004</td> <td>Empty port</td> </tr> <tr> <td>005</td> <td>Empty port</td> </tr> </table> <div style="display: flex; justify-content: space-between; align-items: center; margin-top: 5px;"> ✓ ▽ ▲ </div>	001	Changed module : SOUNDER CLASS A	002	Empty port	003	Empty port	004	Empty port	005	Empty port	<p>The panel has detected a different type of module fitted to a port that was previously occupied.</p>
001	Changed module : SOUNDER CLASS A										
002	Empty port										
003	Empty port										
004	Empty port										
005	Empty port										
<table border="1" style="width: 100%; border-collapse: collapse;"> <tr> <td style="width: 5%;">001</td> <td style="background-color: #FFFF00;">Serial Number Changed : LOOP</td> </tr> <tr> <td>002</td> <td>Empty port</td> </tr> <tr> <td>003</td> <td>Empty port</td> </tr> <tr> <td>004</td> <td>Empty port</td> </tr> <tr> <td>005</td> <td>Empty port</td> </tr> </table> <div style="display: flex; justify-content: space-between; align-items: center; margin-top: 5px;"> ✓ ▽ ▲ </div>	001	Serial Number Changed : LOOP	002	Empty port	003	Empty port	004	Empty port	005	Empty port	<p>The panel has detected a module fitted to a port that is the same type, but it's serial number has changed.</p> <p>This could happen if a loop module was swapped with another one, for example.</p>
001	Serial Number Changed : LOOP										
002	Empty port										
003	Empty port										
004	Empty port										
005	Empty port										
<table border="1" style="width: 100%; border-collapse: collapse;"> <tr> <td style="width: 5%;">001</td> <td style="background-color: #FFFF00;">Removed Module : LOOP</td> </tr> <tr> <td>002</td> <td>Empty port</td> </tr> <tr> <td>003</td> <td>Empty port</td> </tr> <tr> <td>004</td> <td>Empty port</td> </tr> <tr> <td>005</td> <td>Empty port</td> </tr> </table> <div style="display: flex; justify-content: space-between; align-items: center; margin-top: 5px;"> ✓ ▽ ▲ </div>	001	Removed Module : LOOP	002	Empty port	003	Empty port	004	Empty port	005	Empty port	<p>The panel has detected no module fitted to a port that was previously occupied.</p>
001	Removed Module : LOOP										
002	Empty port										
003	Empty port										
004	Empty port										
005	Empty port										

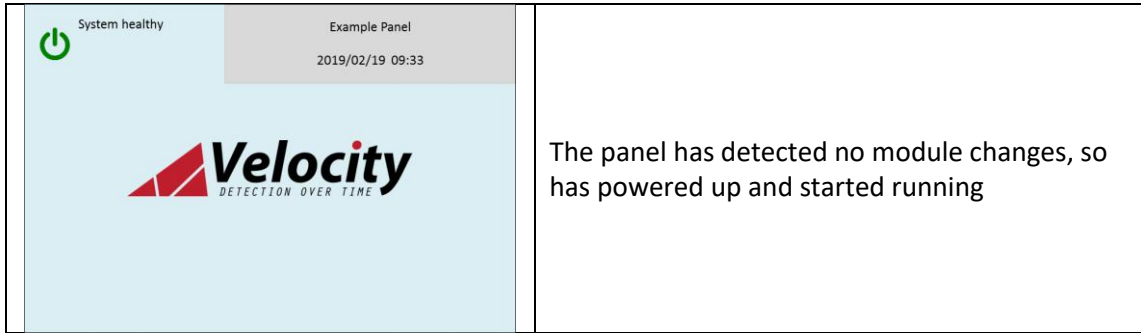

1. Check that the module configuration is as expected using the ▲ and ▼ to navigate the through the port numbers. Press the ✓ icon to confirm the changes.
2. The new module is now configured into the panel and is ready for use.
3. Since the batteries are not connected, the panel will report them as removed, lighting the yellow “Trouble” LED, intermittently sounding the trouble buzzer, and displaying battery removed message on the screen.
4. Connect the batteries, ensuring that the polarity is correct (Red wire = +ve) & (Black wire = -ve). Acknowledge the trouble event via the display screen, and reset the panel to clear the battery fault.
5. The panel should now remain in the normal condition, and you can configure the panel as normal.

Field Wiring

i **NOTE:** The terminal blocks are removable to make wiring easier.

! **ATTENTION:** DO NOT EXCEED POWER SUPPLY RATINGS, OR MAXIMUM CURRENT RATINGS.

Class X Wiring

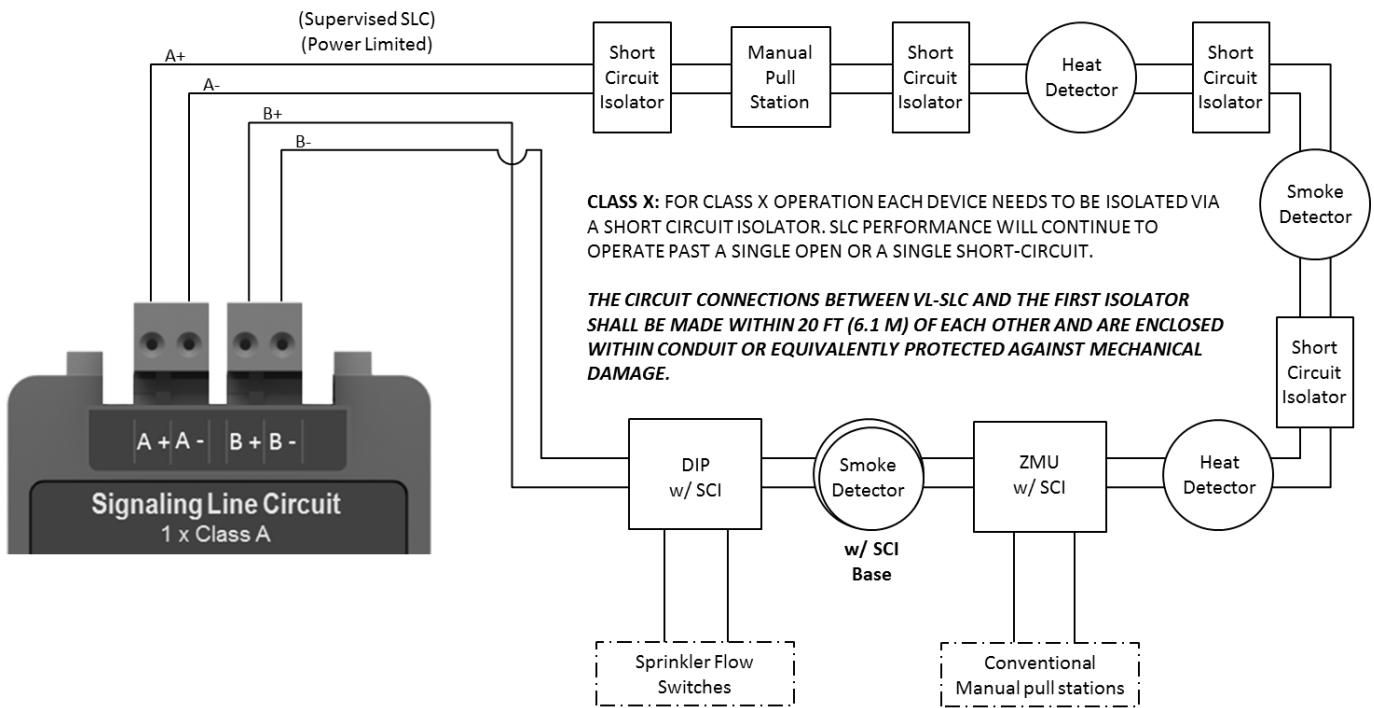



Note: Detectors can be fitted to isolator bases, or fitted between isolator modules for Class X wiring. Manual stations should be fitted between isolator modules.

Class A Wiring

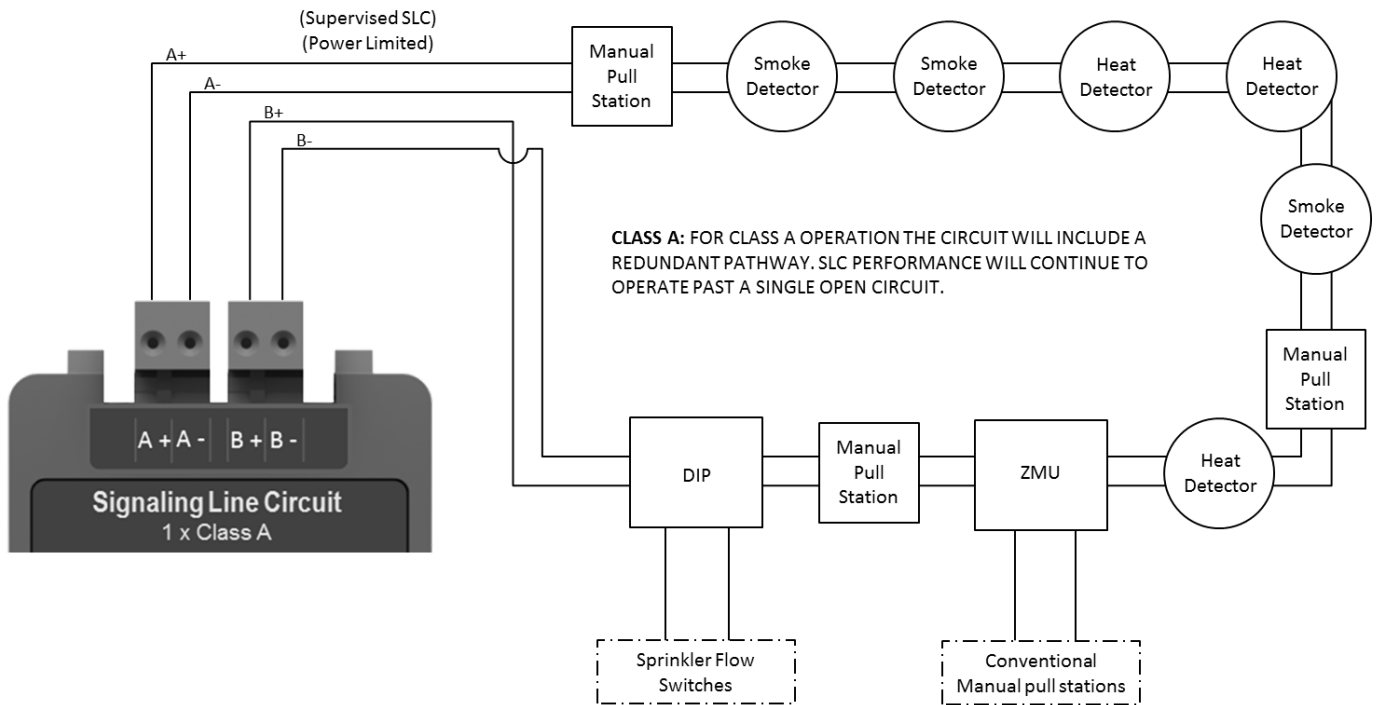

Note: If an SLC using Class A wiring is used for 2 or more detection zones, short circuit isolators, or devices with built in short circuit isolators (such as interfaces) should be fitted to the zone boundaries to prevent a single short circuit affecting more than one zone.

Wiring recommendations

The VL-SLC's are rated for 500mA each, but in a typical UL installation (with no NAC devices powered from the loop, maximum quiescent current will be less than 60mA.

Wire Gauge (AWG)	Maximum Wiring Run (Metres)
18	861
16	1290
14	2000



RECOMMENDED CABLE: Twisted pair cable. Shield of cable should be terminated to the earth bar in the panel.



NOTE:

- Line capacitance shall not exceed 0.1µf (100nF)
- Inductance shall not exceed 1mH
- Resistance shall not exceed 50 Ohms.

Front Unit LED Indications

LED Indication	Description
Wire Break + (Yellow)	Illuminated yellow when a loop break on the positive line is detected.
Wire Break - (Yellow)	Illuminated yellow when a loop break on the negative line is detected.
Short A (Yellow)	Illuminated yellow when a short circuit on the loop A side is detected.
Short B (Yellow)	Illuminated yellow when a short circuit on the loop B side is detected.
Loop TX (Green)	Flashing green when the loop card is transmitting information.
Loop RX (Green)	Flashing green when the loop card is receiving information.
Com. (Green)	Pulses to show communication between the module and the motherboard.

Specifications

Specification	VL-SLC	
Part Number	62-400	
Design Standard	UL864 10 th Edition	
Approval	UL Laboratories	
Supply Voltage	24V DC Nominal	
Loop Voltage	35VDC Nominal	
Maximum SLC Current	200mA	500mA
Maximum SLC Resistance	50Ω (25Ω per core)	20Ω (10Ω per core)
Maximum SLC Capacity	254 Addresses	
Maximum SLC Cable Length	*2KM	
Maximum SLC Capacitance	100nF	
Maximum SLC Baud Rate	4334 bits per second (typical)	
Maximum Ground Fault Impedance	10KΩ	
Wiring Class	Class X or Class A [Power limited & Supervised]	
Operating Temperature	0°C (32°F) to 49°C (120°F)	
Max Humidity	93% Non-Condensing	
Size (mm) (HxWxD)	105mm x 57mm x 47mm	
Weight	0.15KG	
Recommended Cable Sizes	18 AWG to 14 AWG (0.8mm ² to 2.5mm ²)	

*Depending on what cable size is used. A 2KM maximum SLC distance is assuming 2.5mm² (14AWG) cables is used.

Compatible Devices/Accessories

Model No.	Description
VDOT-PY	Addressable Photoelectric Smoke Detector (6 th Edition)
VDOT-PY3	Addressable Photoelectric Smoke Detector (7 th Edition)
VDOT-PYH	Addressable Multisensory Detector (6 th Edition)
VDOT-PYH3	Addressable Multisensory Detector (7 th Edition)
VDOT-H2 / VDOT-H3	Addressable Heat Detector
VDOT-H2-H/VDOT-H3-H	Addressable High Temperature Heat Detector
VDOT-DPH	Addressable Dual Optical/Heat Detector
VDOT-MiniIP	Addressable Mini Input Module
VDOT-DIP-SCI	Addressable Dual Input Module with SCI
VDOT-DOP-SCI	Addressable Relay Dual Output with SCI
VDOT-DOP-AC240V-SCI	Addressable Relay Dual Output Module for AC240v with SCI
VDOT-ZMU	Addressable Conventional Zone Module with SCI
VDOT-S6	Addressable Sounder Base
VDOT-SCI	Short Circuit Isolator
VDOT-STB-RL	Low Power Relay Base
VDOT-STB-SCI	Short Circuit Isolator Base
VDOT-UB4	Standard Detector Mounting 4" Base
VDOT-UB4-6	Standard Detector Mounting 6" Base
VDOT-ADP	Adaptor Plate
VDOT-AD2	Handheld Address Programmer

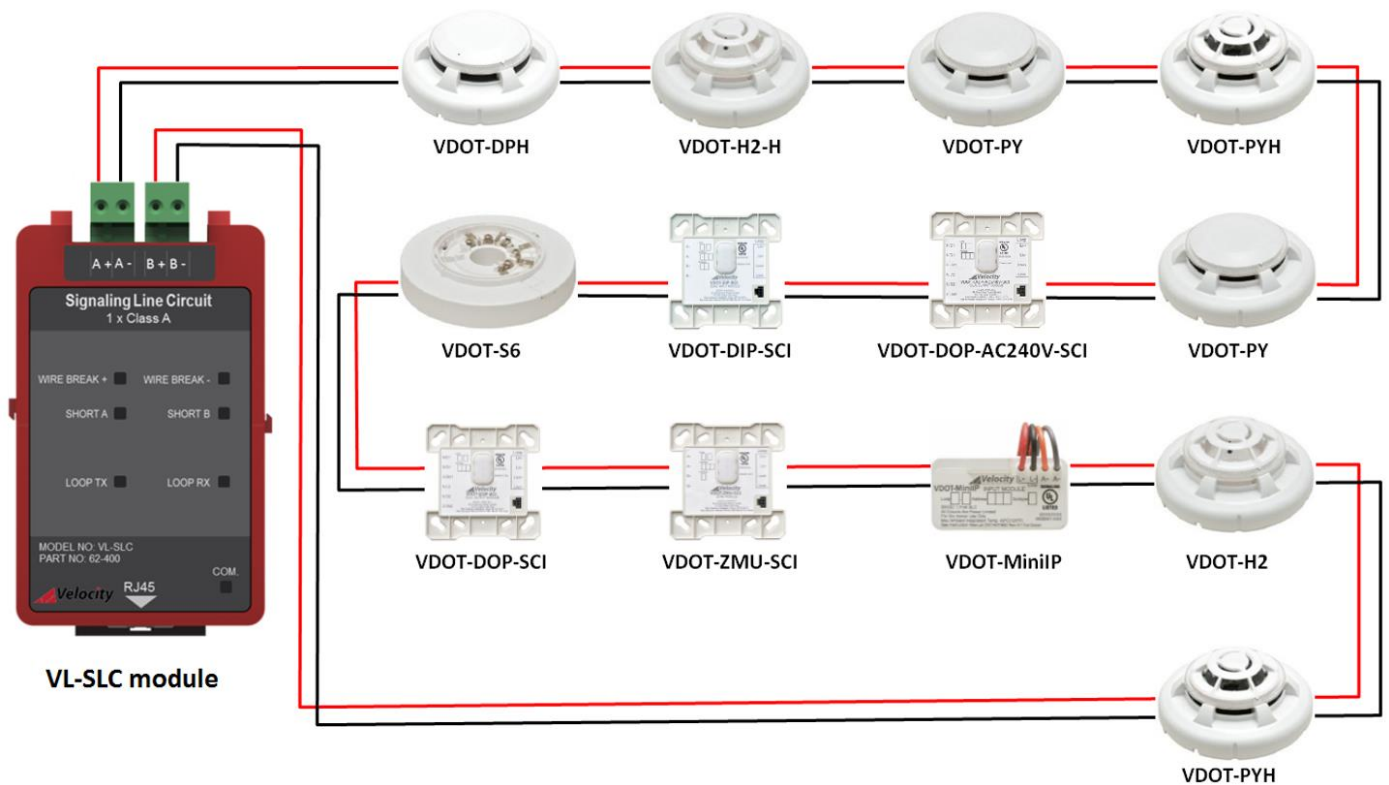

Note: If an SLC using Class A wiring is used for 2 or more detection zones, short circuit isolators, or devices with built in short circuit isolators (such as interfaces) should be fitted to the zone boundaries to prevent a single short circuit affecting more than one zone.