

Instruction Manual
VDOT-STB-SCI
Short Circuit Isolator Base



ZETA ALARMS LIMITED
72-78 MORFA ROAD, SWANSEA, SA1 2EN
<http://www.velocitydetection.com>

Before Installation

Please read these instructions carefully and keep for future reference.

The information in this document is subject to change without notice. For updates please refer to our website.

⚠ CAUTION

Do not use the products outside the rated power supply voltage range specified in the Specifications. It may cause a fire or damage to equipment.

⚠ CAUTION

Do not disassemble, repair, or modify the products. It may cause a fire or electric shock.

⚠ CAUTION

Make sure to turn the power off before commencing any wiring work. Otherwise it may cause electric shock or damage to equipment.

Note: Follow the requirements for the installation of the products in accordance with the Specifications. Otherwise it may cause damage to equipment.

Note: Do not install the product in any location where oil, dust, iron powder, chemicals, or hydrogen sulphide may occur or affect the product. It may cause damage to equipment.

Section 1 – INTRODUCTION

VDOT-STB-SCI is a detector base with short circuit isolator for use with Zeta Control Panel series, which does not require an address. The detector base isolates short-circuit to protect detectors from failing. When short-circuit is detected LED indicator illuminates, and short-circuited area is isolated automatically. Upon removal of the short condition, the area is automatically connected to go back to the normal standby status.

Section 2 – TERMINALS

VDOT-STB-SCI base is supplied with 3 terminals as standard. The terminals of VDOT-STB-SCI base head are configured as follows:

- Terminal 1 = SLC positive
- Terminal 6 = SLC negative IN
- Terminal 5 = SLC negative OUT

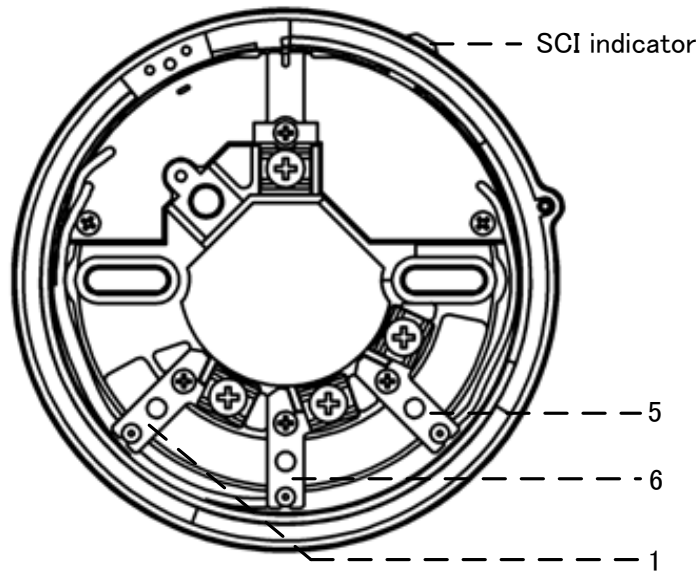

Figure 1: Position of terminals

Section 3 – DIMENSIONS

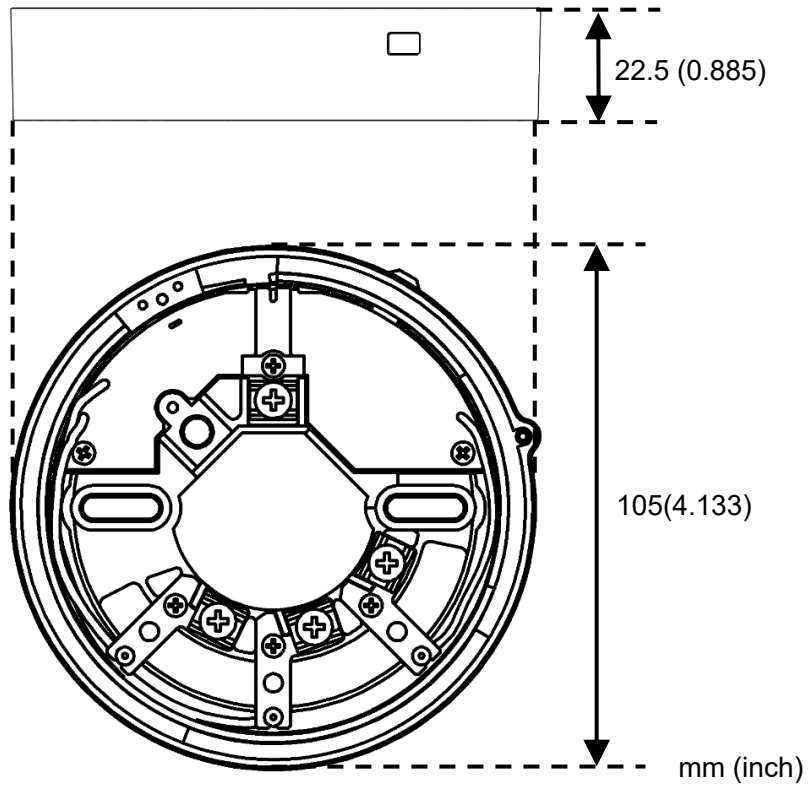

Figure 2: Dimension of VDOT-STB-SCI

Section 4 – DETECTOR MODELS

VDOT-STB-SCI Base is available for use with the VDOT series detectors. It is important to use the correct detector for each application. The standard range of detectors available is as follows:

Model	Description	Instruction Manual
VDOT-PY	Analog addressable photoelectric smoke detector	GLT-299-7-1
VDOT-PYH	Analog addressable combination photoelectric smoke and heat detector 57°C (135° F) with 8.3°C (15°F) rate of rise	GLT-299-7-4
VDOT-H2	Analog addressable heat detector 57°C (135° F) with 8.3°C(15°F) rate of rise	GLT-299-7-2
VDOT-DPH	Analog addressable combination photoelectric smoke (dual wave length) and heat detector 57°C (135° F) with 8.3°C(15°F) rate of rise	GLT-299-7-5

Optional accessory

VDOT-ADP adapter: Use this adapter when VDOT-STB-SCI is installed with a 4” square electrical box or 4” octagonal electrical box. (Refer to “VDOT-ADP Instruction Manual” for details.)

Section 5 – INSTALLATION

The product must be installed in accordance with the applicable NFPA standards, local codes and jurisdictional authorities. Failure to follow these instructions may result in failure of the detector to report an alarm condition.

Note: ZETA ALARMS LIMITED is not responsible for the product which is improperly installed, maintained and tested.

Note: Use the VDOT-ADP adapter for a 4” square electrical box or 4” octagonal electrical box. VDOT-ADP adaptor is not used for a 3-1/2” octagonal electrical box.

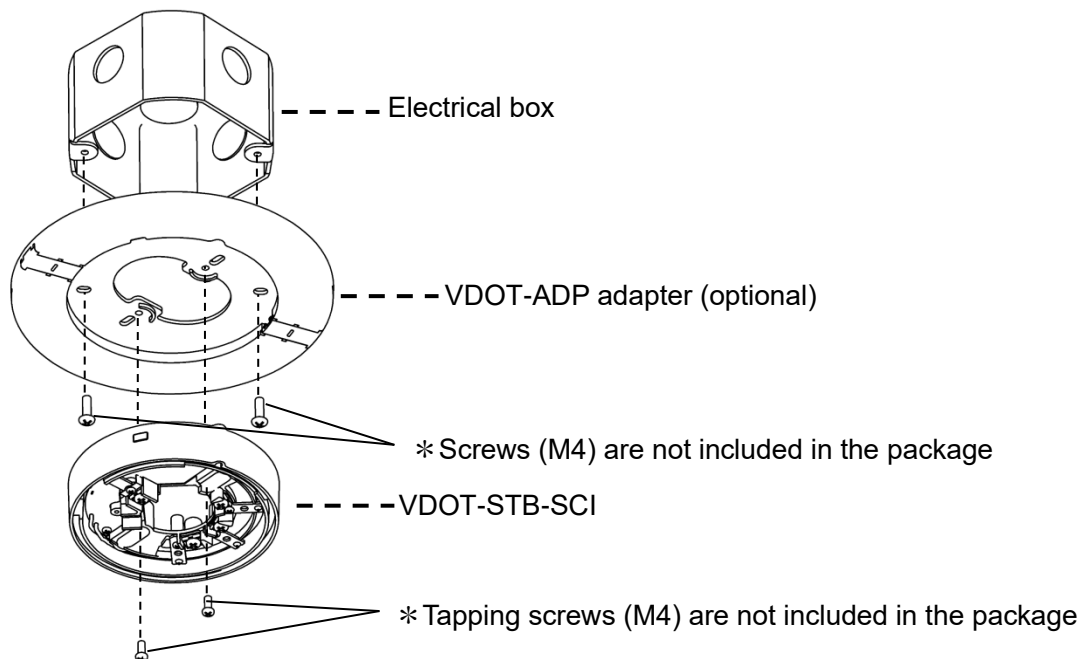

Figure 3: Installation to an electrical box

Section 6 – CONNECTIONS

Install wiring in accordance with Figure 4 in this document.

All wiring must conform to applicable local codes, ordinances, and regulations.

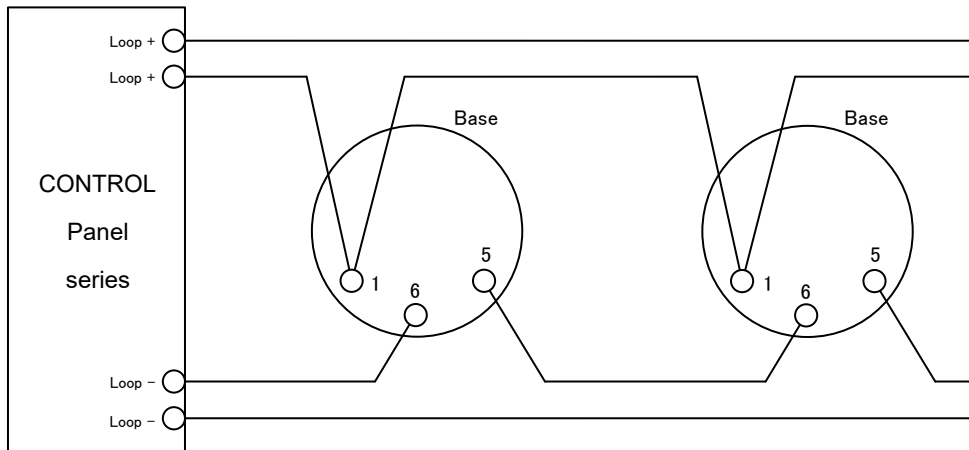

Figure 4: Connection to Zeta control panel series

CAUTION

Use cable AWG12-20 for wiring. Do not connect different gauge cables at one terminal in order to prevent loosening.

CAUTION

Do not connect cables in reverse polarity. Failure to connect the polarity correctly could result in damage to the base and/or other equipment.

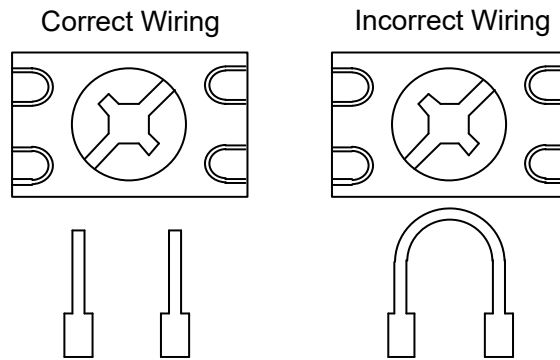

Figure 5: Connection to terminals

CAUTION

For system monitoring - for terminals 1, 5, and 6, do not use looped wire under terminals. Break wire run to provide monitoring of connections.

Before installing the product check the continuity, polarity and insulation resistance of all wiring. Check that siting is in accordance with the site system drawings and conforms to all applicable local codes such as NFPA 72.

In normal use, the **VDOT-STB-SCI** base will be installed at ceiling level. Pass the field wiring through the cable hole in the center and from the rear of the base. Hold and affix the base to the ceiling or electrical box with screws via the base mounting holes. Connect the field wiring to the base terminals, as detailed in Section 5 and 6,

making sure the wiring does not obstruct fitting of the detector head.

Fit the detector head by inserting it into the base and turning clockwise until the notch in the detector rim aligns with base locking screws. To avoid unauthorized de-installation, turn the locking screw counterclockwise until the screw comes to about 4mm(3/16") from the rim of the base, as shown in Figure 6. The OMNIVIEW™ 360° indicator permits visibility from any angle.

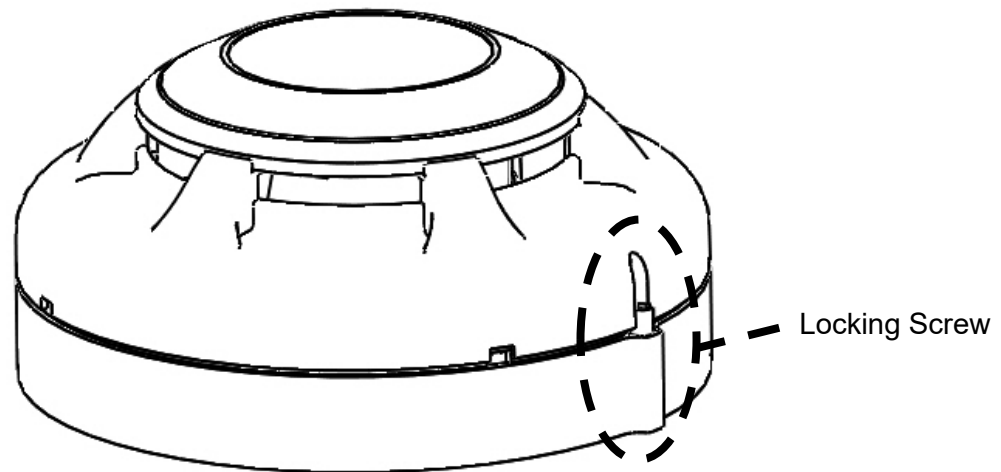

Figure 6: Position of locking screw

Note: Smoke and heat detectors are not to be used with detector guards unless the combination has been evaluated and found suitable for that purpose.

Section 7 – MAINTENANCE

Maintenance

The **VDOT-STB-SCI** is a high quality product engineered for reliability. In order to obtain optimum performance, periodic maintenance is required, at least in accordance with NFPA 72 chapter 14 "Inspection, Testing and Maintenance".

Routine Inspection:

Ensure the detector head and the base are secure and undamaged.

Operation Test:

The purpose of the Operational Test is to confirm the product's correct operation.

- 1) When carrying out site testing of the product, the control panel shall be set to "one-man-walk test mode" prior to the test.
- 2) Take any necessary precautions to limit the sounding of the alarm sounders/bells and any fire service summoning device.
- 3) Detach the detector connected with the base.

- 4) Short between terminal 1 and 5, and the yellow SCI indicator is illuminated. The short circuit isolator isolates the devices connected after the short-circuited area, which makes these devices have no response. Upon removal of the short condition, the area is automatically connected to go back to the normal operating status, and the SCI indicator turns off.

Note: For detector testing and cleaning information, refer to each detector's instruction manual as mentioned in Section 4.

Section 8 – SPECIFICATIONS

SLC Applied Voltage	Rated Range 20VDC to 38VDC
SLC Current Consumption	Standby 100 μ A Activated(SCI Isolation) 22mA
SLC Line impedance	Up to 50ohms, 2km(1.24mile) (Refer to * below)
SCI On Resistance	0.2ohms (max)
SCI Fault Detection Voltage	10V (min)
Visual Indicator (Status LED)	SCI LED (yellow)
UL Ambient Installation Temperature	0°C(32°F) to 38°C(100°F)
Operating Temperature	-10°C(14° F) to 55°C(131°F)
Storage Temperature	-20°C(-4° F) to 60°C(140° F)
Max Relative Humidity	Up to 95% RH, non-condensing
Environment	Indoor dry use only
Terminal	Terminal for SLC: AWG12 to 20
Dimensions	ϕ 105 mm x 22.5 mm H (ϕ 4.133" x 0.885" H) (Mount to a 3-1/2" octagonal box)
Weight	Approximately 79g (2.8 ounces)
Standard	UL268 and UL521

* Refer to the Installation and Operation Manual of Zeta Control Panel series to determine correct loop load and maximum loop resistance for devices connected to each loop.

FOR WARRANTY SERVICE, RETURN TO:
ZETA ALARMS LIMITED
72-78 MORFA ROAD, SWANSEA, SA1 2EN
<http://www.zetaalarmsystems.com>

Section 9 – WARRANTIES

1.1 Zeta warrants to the customers that:

- (a) all products supplied hereunder will be of merchantable quality and will comply with any specification agreed between Zeta and customer.
- (b) it is not aware of any rights of any third party in the market which would or might render the sale of the products, or the use of any of the trade marks on or in products, or the use of any of the trade marks on or in relation to the products, unlawful.

1.2 In the event of any breach of the Zeta's warranty in Clause 1.1(a) whether by reason of defective materials, production faults or otherwise, Zeta's liability shall be limited to:

- (a) replacement of the products in question; or
 - (b) at the Zeta's option, repayment of the price where this had been paid.
- And the warranty period is three (3) years from the shipment from Zeta's factory.

1.3 Notwithstanding anything to the contrary in this warranty terms, Zeta shall not be liable to the customer by reason of any representation or implied warranty, condition or other term or any duty at common law, or under the express terms of this warranty terms, for any consequential loss or damage whether for loss of profit or otherwise and whether occasioned by the negligence of Zeta or its employees or agents or otherwise, arising out of or in connection with any act or omission of Zeta relating to Zeta or supply of the products, their use by any customer.

1.4 Customer shall indemnify Zeta against all loss, damages, liabilities, costs and expenses which Zeta may suffer or incur as a result of or in connection with any breach by customer of this warranties terms or any laws or regulations of any jurisdiction or any rules of any governing authorities.