

General

The VL-ZMA is a three zone monitor module that is designed to be DIN mounted inside of a Velocity control panel. It's powered and interfaced to the Velocity MMP via a RJ45 connection. The module has three class A zone monitors which can be typically used for conventional devices and/or for special detectors that are not available in addressable form such as UV detectors, aspiration and beam detectors etc. The module monitors and transmits the status (normal, open, short, or alarm) of zones with the detectors to a control panel. Each zone input can be programmed to either give a supervisory or alarm signal when active.

Installation



ATTENTION: THE PANEL MUST BE POWERED DOWN, AND DISCONNECTED FROM THE BATTERIES BEFORE INSTALLING OR REMOVING ANY MODULES.

1. Ensure that the installation area is free from any cables or wires that may get caught, and that there is enough space on the DIN rail to mount the module. Also ensure that the DIN clip underneath the module is in the open position.
2. Place the module onto the DIN rail, hooking the metal earth clip underneath onto the rail first.
3. Once the earth clip is hooked, push the bottom of the module onto the rail so that the module sits flat.
4. Push the plastic DIN clip (located at the bottom of the module) upwards to lock and secure the module into position.

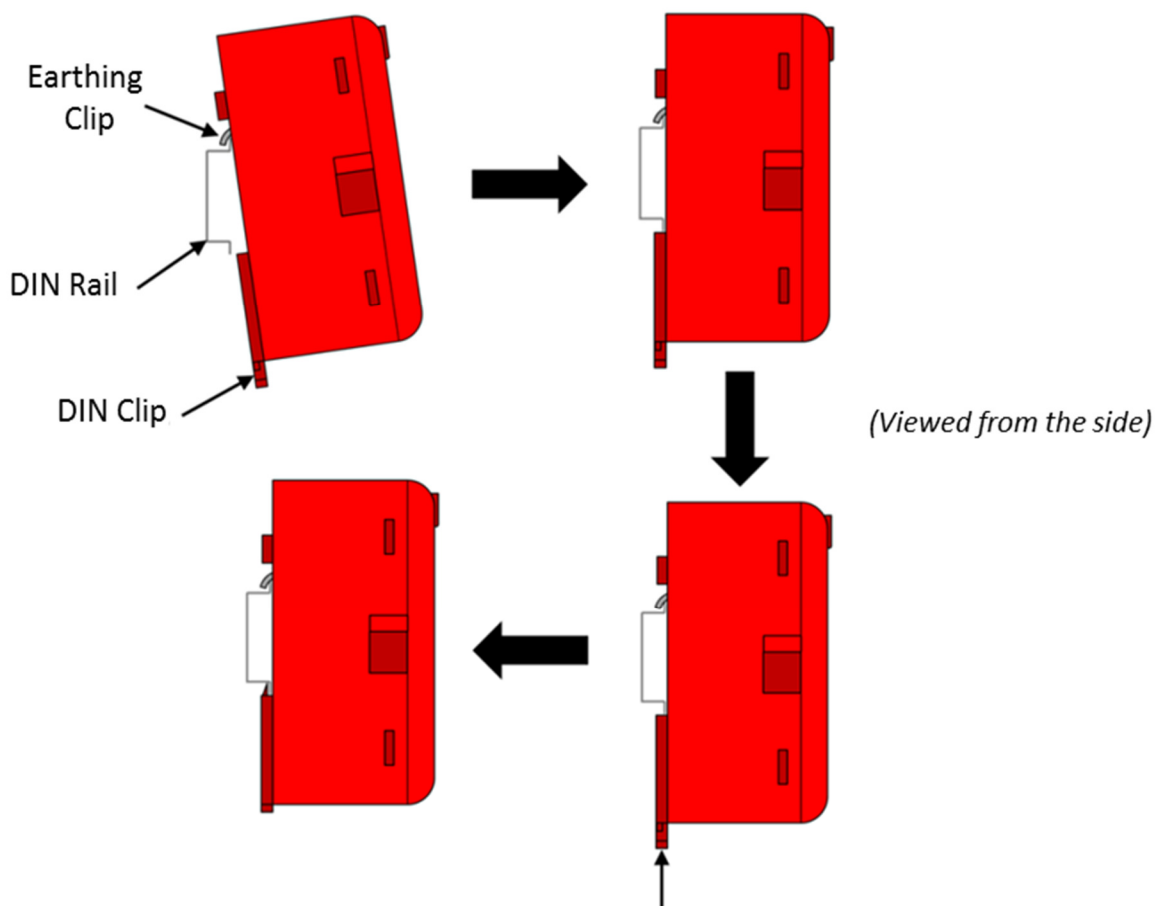

5. Once the module is secured to the DIN rail, simply connect the supplied CAT5E cable to the module's RJ45 port.
6. Connect the other end of CAT5E cable to the nearest unoccupied RJ45 port on the termination PCB.

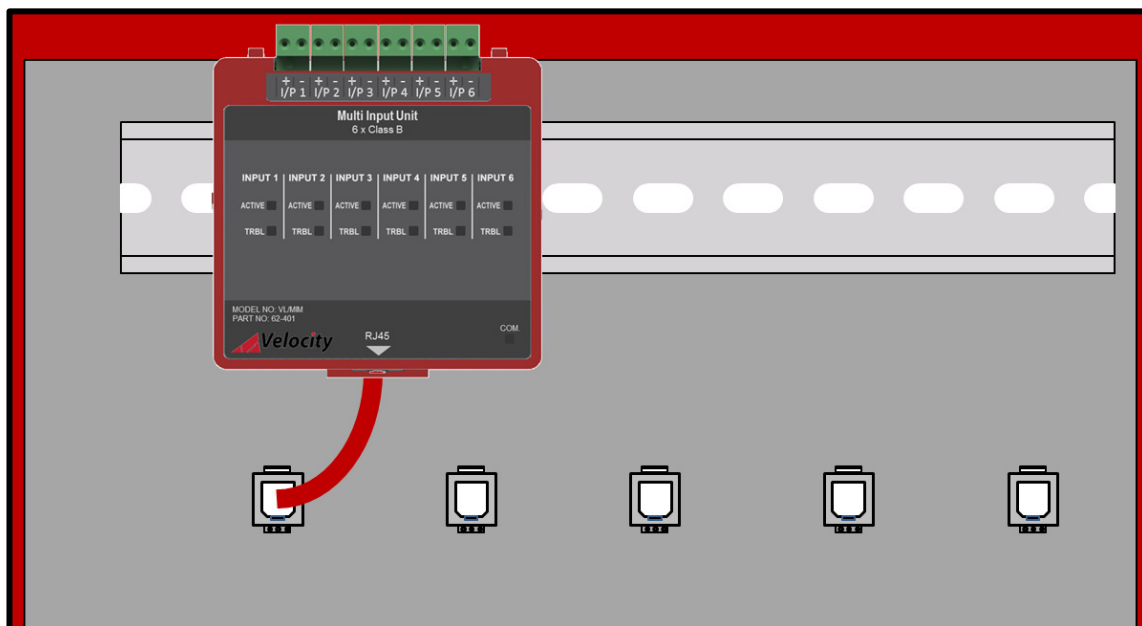

TRM RJ45 Port Address Designation

Each RJ45 port on the Velocity termination has its own unique port address. This port address is important to keep note of as it is displayed on Alarm/Trouble messages and is used when configuring or setting up cause and effects on the panel (See Velocity MMP operation manual GLT-261-7-2).

Securing the modules

The modules are designed to clip together to make them more secure. In addition, the MMP panel is supplied with Din rail stoppers. These should be fitted before the first module, and after the last module on each rail.

Before Powering the Panel On

1. To prevent the risk of a spark, do not connect the batteries. Only connect the batteries after powering on the system from its main AC supply.
2. Check that all external field wiring is clear from any open, shorts and ground faults.
3. Check that all the modules have been installed properly, with correct connections and placement
4. Check that all switches and jumper links are at their correct settings.
5. Check that all interconnection cables are plugged in properly, and that they are secure.
6. Check that the AC power wiring is correct.
7. Ensure that the panel chassis has been correctly earth grounded (See NFPA 70).

Before powering on from the main AC supply, make sure that the front panel door is closed

Power on Procedure

1. After the above has been completed, turn the panel on (Via AC Only). The panel will follow the same power up sequence described in initial power up section above
2. The panel will now display one of the following messages

Message	Meaning										
 <p style="text-align: center;">No Modules</p>	<p>Panel has not detected any modules fitted during its power up check.</p> <p>Power down the panel and check that the expected modules are fitted, and that all module cables are correctly inserted.</p> <p>Note that the panel will need at least one module fitted to run.</p>										
<table border="1" style="width: 100%; border-collapse: collapse;"> <tr> <td style="width: 5%;">001</td> <td style="background-color: #00FF00;">New module : SOUNDER CLASS A</td> </tr> <tr> <td>002</td> <td>Empty port</td> </tr> <tr> <td>003</td> <td>Empty port</td> </tr> <tr> <td>004</td> <td>Empty port</td> </tr> <tr> <td>005</td> <td>Empty port</td> </tr> </table> <p style="text-align: center;"> ✓ ▽ ▲ </p>	001	New module : SOUNDER CLASS A	002	Empty port	003	Empty port	004	Empty port	005	Empty port	<p>The panel has detected a new module added to a port that was previously empty.</p> <p>This is the usual message seen the first time a panel is configured</p>
001	New module : SOUNDER CLASS A										
002	Empty port										
003	Empty port										
004	Empty port										
005	Empty port										
<table border="1" style="width: 100%; border-collapse: collapse;"> <tr> <td style="width: 5%;">001</td> <td style="background-color: #FFFF00;">Changed module : SOUNDER CLASS A</td> </tr> <tr> <td>002</td> <td>Empty port</td> </tr> <tr> <td>003</td> <td>Empty port</td> </tr> <tr> <td>004</td> <td>Empty port</td> </tr> <tr> <td>005</td> <td>Empty port</td> </tr> </table> <p style="text-align: center;"> ✓ ▽ ▲ </p>	001	Changed module : SOUNDER CLASS A	002	Empty port	003	Empty port	004	Empty port	005	Empty port	<p>The panel has detected a different type of module fitted to a port that was previously occupied.</p>
001	Changed module : SOUNDER CLASS A										
002	Empty port										
003	Empty port										
004	Empty port										
005	Empty port										
<table border="1" style="width: 100%; border-collapse: collapse;"> <tr> <td style="width: 5%;">001</td> <td style="background-color: #FFFF00;">Serial Number Changed : LOOP</td> </tr> <tr> <td>002</td> <td>Empty port</td> </tr> <tr> <td>003</td> <td>Empty port</td> </tr> <tr> <td>004</td> <td>Empty port</td> </tr> <tr> <td>005</td> <td>Empty port</td> </tr> </table> <p style="text-align: center;"> ✓ ▽ ▲ </p>	001	Serial Number Changed : LOOP	002	Empty port	003	Empty port	004	Empty port	005	Empty port	<p>The panel has detected a module fitted to a port that is the same type, but it's serial number has changed.</p> <p>This could happen if a loop module was swapped with another one, for example.</p>
001	Serial Number Changed : LOOP										
002	Empty port										
003	Empty port										
004	Empty port										
005	Empty port										
<table border="1" style="width: 100%; border-collapse: collapse;"> <tr> <td style="width: 5%;">001</td> <td style="background-color: #FFFF00;">Removed Module : LOOP</td> </tr> <tr> <td>002</td> <td>Empty port</td> </tr> <tr> <td>003</td> <td>Empty port</td> </tr> <tr> <td>004</td> <td>Empty port</td> </tr> <tr> <td>005</td> <td>Empty port</td> </tr> </table> <p style="text-align: center;"> ✓ ▽ ▲ </p>	001	Removed Module : LOOP	002	Empty port	003	Empty port	004	Empty port	005	Empty port	<p>The panel has detected no module fitted to a port that was previously occupied.</p>
001	Removed Module : LOOP										
002	Empty port										
003	Empty port										
004	Empty port										
005	Empty port										

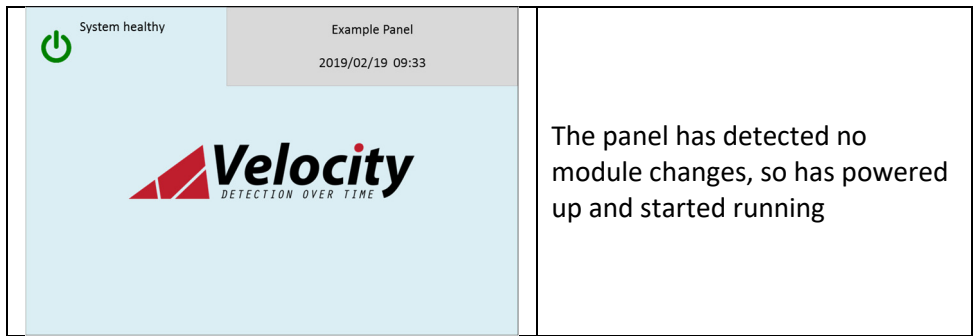

1. Check that the module configuration is as expected using the ▲ and ▼ to navigate the through the port numbers. Press the ✓ icon to confirm the changes.
2. The new module is now configured into the panel and is ready for use.
3. Since the batteries are not connected, the panel will report them as removed, lighting the yellow “Trouble” LED, intermittently sounding the trouble buzzer, and displaying battery removed message on the screen.
4. Connect the batteries, ensuring that the polarity is correct (Red wire = +ve) & (Black wire = -ve). Acknowledge the trouble event via the display screen, and reset the panel to clear the battery fault.
5. The panel should now remain in the normal condition, and you can configure the panel as normal.

Field Wiring



NOTE: The terminal blocks are removable to make wiring easier.



ATTENTION: DO NOT EXCEED POWER SUPPLY RATINGS, OR MAXIMUM CURRENT RATINGS.

Class A Wiring



NOTE: It is not recommended to mix different detector manufacturers on a zone.

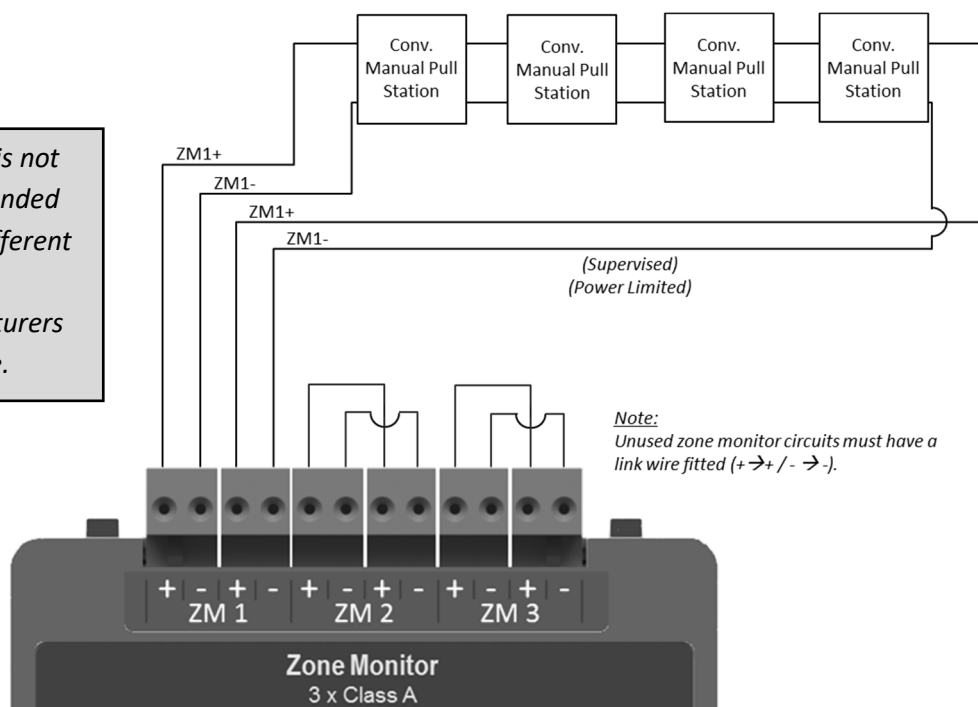

Wiring Recommendations

Wire Gauge (AWG)	Maximum Wiring Run (Metres)
22	910
20	1450
18	2300



RECOMMENDED CABLE:

Cable should be UL listed FPL, FPLR, FPLP or equivalent.

While Velocity conventional Zone modules can support cable runs greater than 2000m, it is generally better to plan the system to use more manageable lengths.

Front Unit LED Indications

LED Indication	Description
Active (Red)	On steady when an alarm on the zone is active.
Short (Yellow)*	Flashing when a short circuit condition has been detected.
Wire Break (Yellow)*	Flashing when an open circuit condition has been detected.
Com. (Green)	Pulses to show communication between the module and the motherboard.

* When a VL-ZMA circuit is disabled, the Short & Wire Break LED's will be on steady (Yellow).

Specifications

Specification	VL-ZMA
Part Number	62-402
Design Standard	UL864 10 th Edition
Approval	UL Laboratories
Wiring Class	3 x Class A [Power limited & Supervised]
Circuit Voltage	29VDC Nominal (19.5 – 30V)
Zone Max Current (under S/C conditions)	56mA
Zone Max Line Impedance	20Ω total (10Ω per core)
Maximum Ground Fault Impedance	10KΩ
End of Line Resistor	N/A
Triggering Resistor	1KΩ
Operating Temperature	0°C (32°F) to 49°C (120°F)
Max Humidity	93% Non-Condensing
Size (mm) (HxWxD)	103mm x 97mm x 46mm
Weight	0.2KG
Recommended Cable Sizes	22 AWG to 14 AWG (0.3mm ² to 2.5mm ²)
Compatible Devices	VR-RS-01 (UL38 listed)
Maximum Devices Per Zone	20